

Supertweeter for outstanding detail and clarity in high-frequencies without harshness. The ST302 may be used individually in lower power systems or arrayed for increased coverage and SPL in higher power systems.

The bullet-shape horn design offers a longer throw 40° x 40° dispersion.

The plastic injected housing is stable and durable.

The phenolic annular diaphragm is long-lasting, cost-effective and more natural-sounding than metallic diaphragms.

The use of high-temperature materials and adhesives improves power handling and produces exceptionally high acoustic output.

A precisely engineered diaphragm structure and alignment mechanism for easy, reliable, cost effective repair in case of diaphragm failure.



SOUND DISPERSION PATTERN

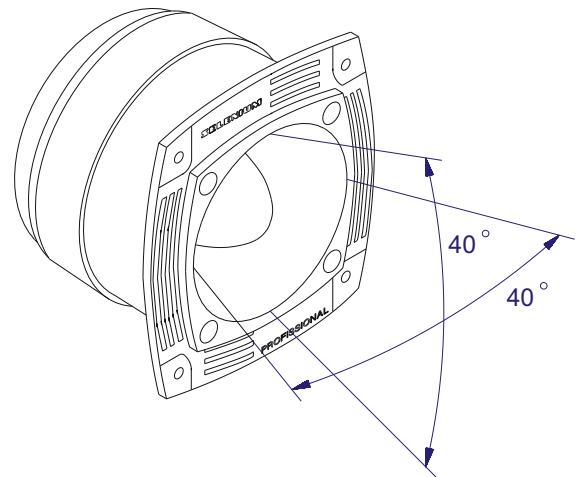

SPECIFICATIONS

Nominal impedance	8	Ω
Minimum impedance @ 8,000 Hz	7.0	Ω
Power handling		
Musical Program (w/ xover 5,000 Hz 12 dB/oct) ¹	50	W
Musical Program (w/ xover 8,000 Hz 12 dB/oct) ¹	100	W
Sensitivity (2.83V@1m) averaged from 5 to 15 kHz	108	dB SPL
Frequency response @ -6 dB	3,500 to 20,000	Hz
Sound dispersion (H x V)	40 x 40	degrees
Diaphragm material		Phenolic
Voice coil diameter	46 (1.8)	mm (in)
Re	6.1	Ω
Flux density	1.70	T

¹ Power handling specifications refer to normal speech and/or music program material, reproduced by an amplifier producing no more than 5% distortion. Power is calculated as true RMS voltage squared divided by the nominal impedance of the loudspeaker. This voltage is measured at the input of the recommended passive crossover when placed between the power amplifier and loudspeaker.
Musical Program= 2 x W RMS

WARNING: Must be connected with an appropriate crossover.

ADDITIONAL INFORMATION

Magnet material	Barium ferrite
Magnet weight	440 (15) g (oz)
Magnet diameter x depth	102 x 14 (4.02 x 0.55) mm (in)
Magnetic assembly weight	1,280 (2.82) g (lb)
Housing material	ABS X17 plastic
Housing finish	Black
Magnetic assembly steel finish	Zinc-plated
Voice coil material	Copper
Voice coil former material	Polyimide (Kapton®)
Voice coil winding length	2.9 (9.5) m (ft)
Voice coil winding depth	2.2 (0.09) mm (in)
Wire temperature coefficient of resistance (α25)	0.00356 1/°C
Volume displaced by tweeter	0.7 (0.025) l (ft ³)
Net weight	1,500 (3.31) g (lb)
Gross weight	1,600 (3.53) g (lb)
Carton dimensions (W x D x H)	12 x 12.6 x 10 (4.7 x 5 x 4) cm (in)

MOUNTING INFORMATION

Number of bolt-holes	4
Bolt-hole dimensions	4.5 x 6 (0.20 x 0.24) mm (in)
Distance between bolt-holes (H x V)	85 x 90 (3.35 x 3.54) mm (in)
Baffle cutout diameter (front mount)	109 (4.30) mm (in)
Connectors	Push terminals
Polarity	Positive voltage applied to the positive terminal (red) gives diaphragm motion toward the horn throat

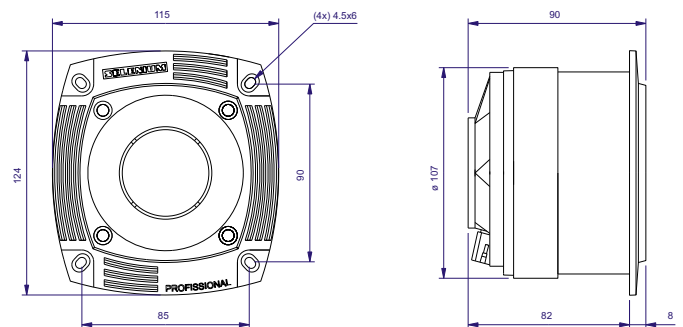

Dimensions in mm.

RESPONSE CURVE MEASURED IN ANECHOIC CHAMBER, 1 W / 1 m

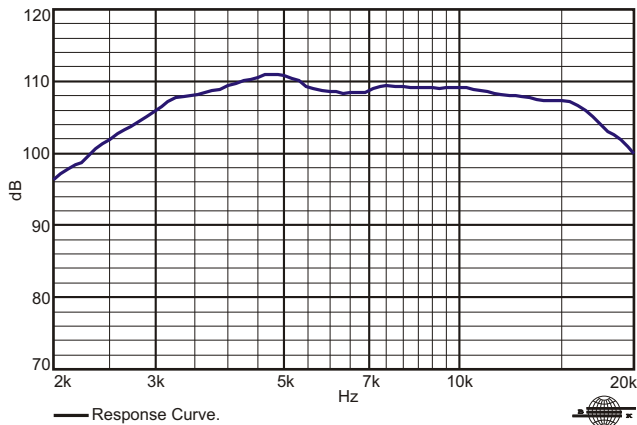

HARMONIC DISTORTION CURVES, 2.5 W / 1 m.

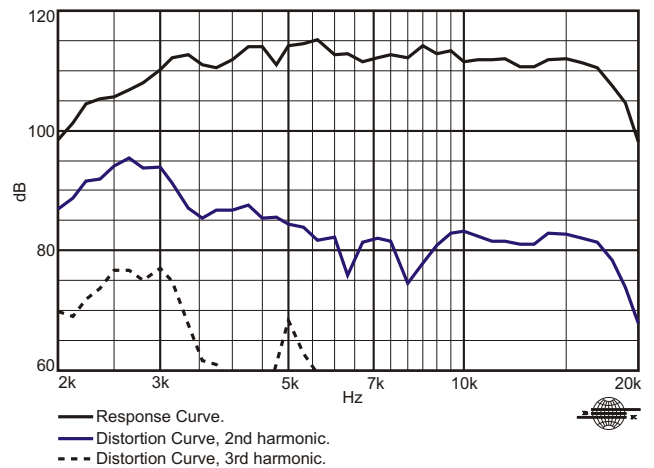

IMPEDANCE AND PHASE CURVES MEASURED IN FREE-AIR.

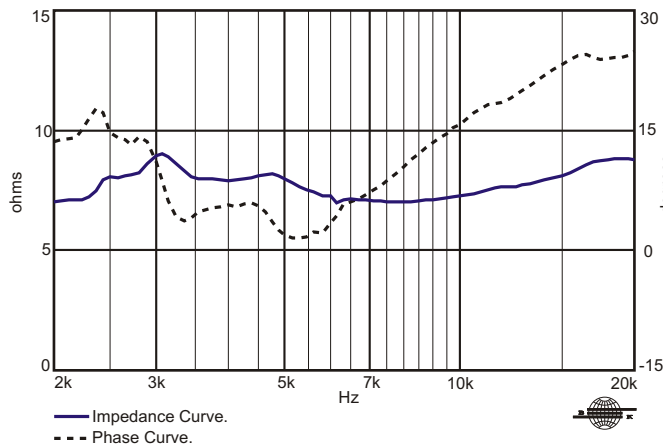

POLAR RESPONSE CURVES

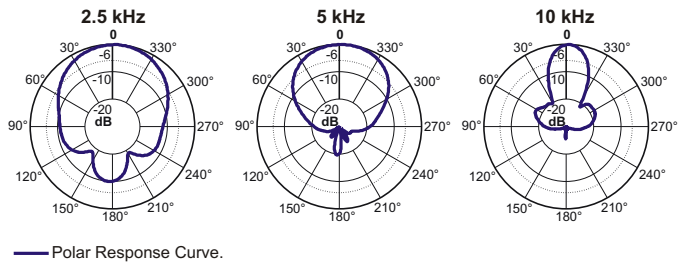

HARMONIC DISTORTION CURVES, 1 W / 1 m.

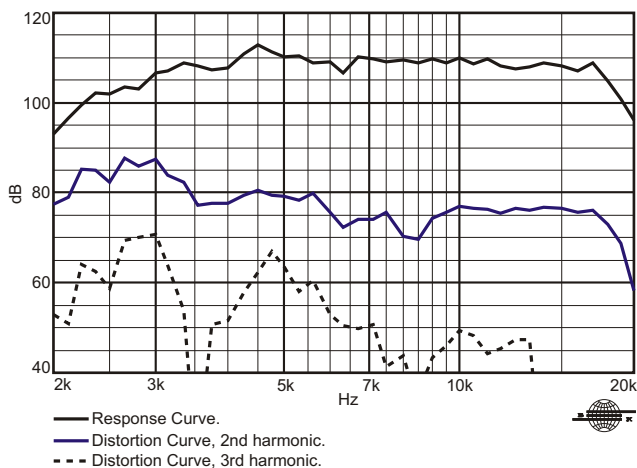

HOW TO CHOOSE THE RIGHT AMPLIFIER

The power amplifier must be able to supply twice the RMS driver power. This 3 dB headroom is necessary to handle the peaks that are common to musical programs. When the amplifier clips those peaks, high distortion arises and this may damage the transducer due to excessive heat. The use of compressors is a good practice to reduce music dynamics to safe levels.

FINDING VOICE COIL TEMPERATURE

It is very important to avoid maximum voice coil temperature. Since moving coil resistance (R_e) varies with temperature according to a well known law, we can calculate the temperature inside the voice coil by measuring the voice coil DC resistance:

$$T_B = T_A + \left(\frac{R_B}{R_A} - 1 \right) \left(T_A - 25 + \frac{1}{\alpha_{25}} \right)$$

T_A, T_B = voice coil temperatures in °C.

R_A, R_B = voice coil resistances at temperatures T_A and T_B , respectively.

α_{25} = voice coil wire temperature coefficient at 25 °C.